

Reflected Energy Compensation

The accurate measurement of low-emissivity objects has been a common difficulty in infrared thermometry, since they reflect energy from the background near the target.

Measurement situations where the ambient temperature of the infrared thermometer differed from the ambient temperature near a low-emissivity target have been particularly difficult, in terms of obtaining absolute measurement accuracy (see Figure 1).

The microprocessor technology employed in Calnex thermometers has allowed the introduction of a feature which enables the user to easily obtain improved measurements under these conditions. The Ambient Temperature (reflected energy) Compensation Feature can be activated at will. By entering the true temperature of the background near such targets, an absolute accuracy better than that with any other method may be achieved. Table 1 illustrates the improvement in accuracy for an 8 to 14 μm instrument for various conditions.

TECHNICAL BACKGROUND

The total energy incident upon the infrared detector consists of three basic parts:

- 1) Energy radiated from the target (e_{RAD})
- 2) Energy reflected from the target (e_{REF})
- 3) Energy radiated from within the cavity of the sensor (e_{CAVITY})

Normally, the microprocessor computes and outputs the target's temperature to the display, using the knowledge of the appropriate energy equations stored in memory, the user's emissivity setting, and the sensor's internal temperature. It assumes that the energy reflected from the target emanates from a background having the same temperature as the internal temperature sensor.

In ambient temperature compensation mode, the microprocessor allows the user to enter the target's background temperature, similar to the way that emissivity is entered. This value is then used in the computation and output of temperature.

APPLICATIONS INVOLVING AMBIENT COMPENSATION MODE.

Targets in or passing through furnaces, ovens, driers and coolers are some examples of applications where the ambient temperature compensation mode can be used to improve the absolute accuracy of the measurements.

The conditions of

- 1) Low emissivity target
- 2) Background ambient temperature near target significantly different than temperature where sensor is held (see Figure 1)

must both be true in deciding whether to activate the mode, otherwise, accurate measurements are obtained without its use.

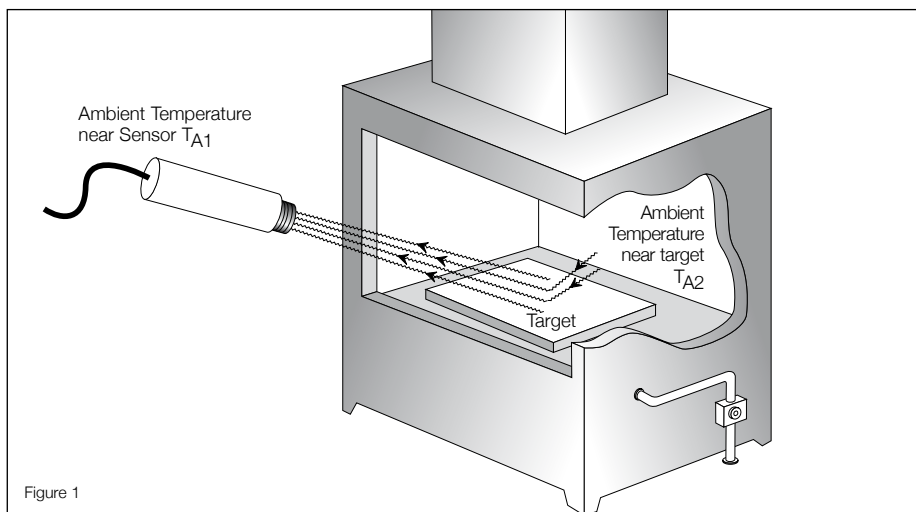

Figure 1

TABLE 1

Actual Target Temperature	Emissivity ϵ	Reflected Temperature (T_{A2})	Indicated Temperature without Compensation	Indicated Temperature with Compensation
93°C	0.8	27°C	93°C	93°C
93°C	0.8	38°C	95°C	93°C
93°C	0.8	149°C	121°C	93°C
93°C	0.6	149°C	161°C	93°C

Note: Internal temperature of IR thermometer assumed to be 27 degrees C.

Explanation:

- 1) No error if IR thermometer internal temperature and ambient temperature near target are the same.
- 2) Error of 2 degrees when ambient near target is 11 degrees higher than ambient of thermometer.
- 3) Increasing error with increasing difference between target and sensor ambient temperatures.
- 4) Increasing error with decreasing emissivity.

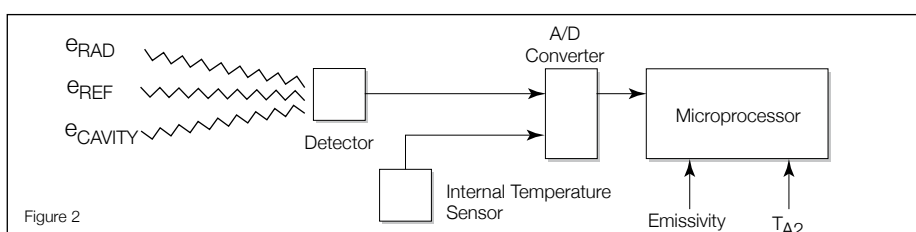

Figure 2