

# Calex 42000 Series

## Operators Guide



Issue B - Feb 10

These power supplies are intended for installation by suitably qualified personnel in enclosures that provide safety protection and as such are not user accessible. They are convection cooled and provision must be made for free air to flow round the unit. They must be mounted on a horizontal DIN rail. It is not abnormal for outer case temperatures to exceed 80°C. Worst case condition temperatures in excess of 100°C may be found.

**AVOID TOUCHING THE CASE WHEN THE UNIT IS POWERED, OR IMMEDIATELY AFTER SWITCHING OFF.**

Additional cooling will improve the long term reliability. This is normally achieved by mounting on a large metal surface, or if this is not possible by fan cooling.

### AC CONNECTION AND FUSING

The 42000 SERIES regulated power supplies have link selectable inputs of 115 V AC or 230 V AC ( $\pm 10\%$ ). See Figures 1 and 2 overleaf.

See input selection table. Inputs must be fused with a slow-blow (T) HBC type fuse. Suitable fuse types to comply with safety approvals WICKMANN 19181, LITTELFUSE Series 215.

### DISCONNECT DEVICES

For PERMANENTLY CONNECTED EQUIPMENT, a readily accessible disconnect device shall be incorporated external to the equipment.

For PLUGGABLE EQUIPMENT, the socket-outlet shall be installed near the equipment and shall be easily accessible.

### OVERLOAD PROTECTION

All models are fitted with foldback current limiting. This feature is factory set at 120% of  $I_{max}$  to minimise the risk of erroneous tripping due to line spikes etc. It is not recommended to run the power supply at greater than  $I_{max}$  continuously.

### PARALLEL CONNECTION

1. Units of the same type may be connected in parallel in order to achieve greater output currents. In simple parallel operation the unit with the highest output voltage will supply the load current up to its limit whereon the next highest will provide the additional current up to its limit etc. To operate safely in this way the current limit should be adjusted to the nominal max unit current to avoid a constant overload situation.

2. In some cases it is desirable to have each supply capable of delivering 100% of the load current (parallel redundant); in this case the units should be connected as shown in figure 3 overleaf.

### TECHNICAL SPECIFICATION

#### Input Voltage

115 or 230 V AC ( $\pm 10\%$ ) link selectable, 50 to 60 Hz

#### Ripple & Noise

<5 mV rms

#### Output Voltage Tolerance

$\pm 5\%$  maximum

#### Load Regulation

$\pm 0.2\%$  for 50% load change

#### Line Regulation

$\pm 0.05\%$  for 10% line change

#### Isolation: Input to Output

3750 V AC minimum

#### Temperature rating

Standard range: 0°C to +50°C full-rated, derated linearly to 40% at 70°C

#### Safety

In accordance with EN60950

#### Overall Dimensions

(l x w x h) 162 x 105 x 98 mm

#### Weight

2.5 kg

#### Material

Steel housing with aluminium base

#### Environmental Rating

IP20

### INPUT CONNECTION DIAGRAM 230 V AC

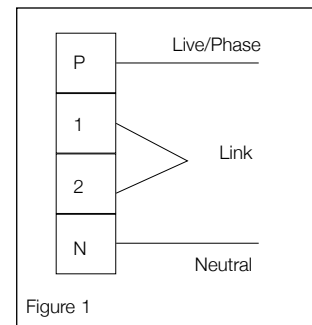

### INPUT CONNECTION DIAGRAM 115 V AC

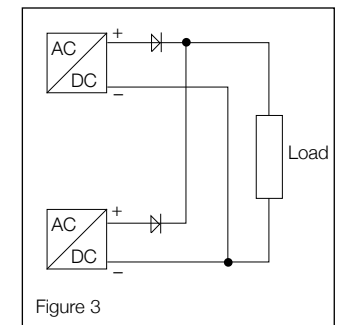
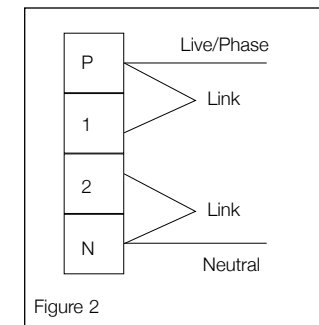

### GENERAL SPECIFICATION

Model	Output V	Output A	Input fuse 115 V	Input fuse 230 V
42024B/3	24	3.0	1.0A	0.5A
42024B	24	4.0	2.0A	1.0A